

# VOLCAN 85



language





# VOLCAN 85 RANGE

A range of professional isodiametric tractors, with standard reversible driving position, made out of 4 different versions each of which is designed and built to fulfil the specific needs of specialised farming:

**AR** – Chassis with central articulation, narrow wheel track and contained turning radii.

**RS** – Chassis with steering wheels, stability and adherence for use also in sloping areas.

**DUALSTEER®** – Chassis with central articulation and steering wheels for unrivalled manoeuvrability in tight spaces.

**MT** – Chassis with steering wheels, configured for haymaking on hills and mountains.

Equipped with a **Stage V 75 hp engine**, the Volcan 85 range is characterised by a **significant technological evolution**, by particular attention to the design, comfort and ergonomics and by **mechanical, hydraulic and electronic upgrades** that make the top machines in the BCS range indispensable tractors for future agriculture.





# CLEAN POWER

The Volcan 85 range is equipped with a **75 hp 4-cylinder Turbo Intercooler engine** with particulate filter, that BCS Group worked on in collaboration with Kohler for an advanced regeneration strategy guaranteeing maximum performance and reducing machine downtime to a minimum.

The **rpm is electronically controlled** quickly and precisely through a console positioned to the right of the steering wheel with these functions:

- increase and decrease engine speed,
- memorize and recall the set speed,
- switch off and switch to minimum speed.



# RENEWED TRANSMISSION

The adoption of a new vehicle control unit that offers very high automotive standards has made it possible to achieve the most from the electro-hydraulic clutch and to equip the Volcan 85 range with some exclusive features:

- **Easy Plus™ clutch:** multidisc in oil bath with hydraulic control is electronically controlled by software that filters any poor use of the clutch pedal by the operator, guaranteeing progressive engagement, without damage and wear.
- **Power Clutch System:** using the button located on the reverser and speed levers, the operator can change the direction of the tractor or change speed without using the clutch pedal, for maximum operating comfort.
- **Smart Brake & Go:** this system, which is activated from a button on the dashboard, makes it possible to stop the tractor and restart using only the brake pedal without using the clutch.

Transmission can optionally be equipped with the exclusive **EasyDrive® electro-hydraulic power shuttle**.

The comfortable reverser lever on the left of the steering wheel allows the operator to **reverse the driving direction without lifting his hands from the steering wheel and without using the clutch pedal**, while keeping the vehicle control at any time and working comfortably.

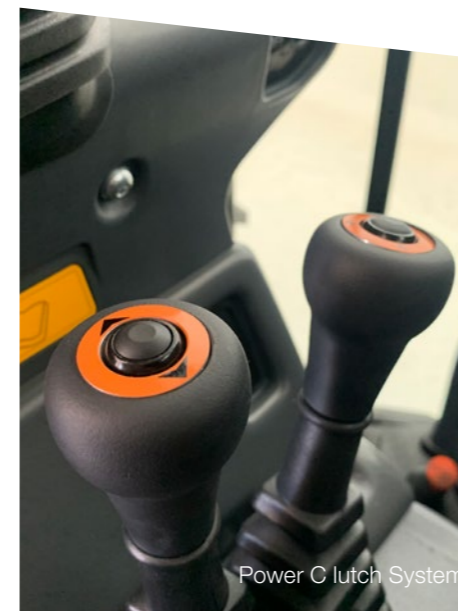

Power C clutch System



Smart Brake &amp; Go

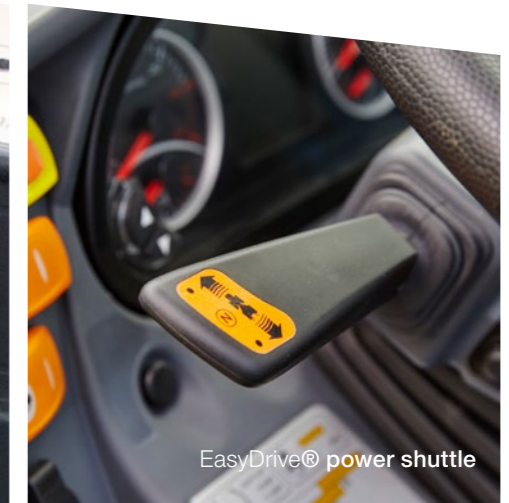

EasyDrive® power shuttle



# DUALSTEER®

To be agile is a crucial characteristic for all specialised tractors. The market demand is therefore to have **machines that are ever more agile and manoeuvrable in tight and narrow spaces**, even on a slope, since it is crucial to be able to operate better and achieve high productivity levels.

The **Dualsteer® version**, unique on the market, offers unrivalled manoeuvrability thanks to the double steering system that combines and synchronises the central joint of the frame with front wheel steering.

This patented system makes it possible to achieve a **steering angle of 70°** to exit and enter the next row with a single manoeuvre with evident time saving, increased production and less compaction of the soil.



## WINNING IN EVERY FIELD OF USE

The unrivalled steering radius combined with the stability during manoeuvres also on slopes, make the **Dualsteer® version** the winning solution in numerous fields of use:

- vineyards and orchards with limited space for manoeuvre at the end of the field
- greenhouse cultivations
- horticultural-floricultural-nursery sector
- greens maintenance and municipality use

THE MOST AGILE IN ITS CATEGORY THANKS TO THE TURNING RADIUS OF JUST 2200 MM

# LIFT AND HYDRAULICS

The hydraulic system features **double circuit with independent pumps and heat exchanger** for oil cooling.

The over-sized flow rate to the pumps (a full 51 l/min in the increased version) allows use with all modern equipment intended for specialised agriculture.

The **rear power take-off** with a multi-disc clutch in oil bath is independent from the gearbox and synchronised with the forwarding speed. It can also be engaged while in motion, from an electro-hydraulic control located on the dashboard with safety system that prevents accidental start-up.

The **sturdy rear lift** uses multipurpose cat. 1 and 2 couplings to fit simply and quickly all attachments available on the market.

A **high performing front lift** is available as an optional, featuring hydraulic outlets, essential when using combined implements.

# JOYSTICK

The new **electronically controlled joystick** uses CAN-bus technology and integrates the PTO engagement button and potentiometer to adjust the hydraulic flow rate.

The adjustable armrest is even more compact, to provide space and comfort to the operator and houses a convenient storage compartment.



HYDR.  
CONTROLLED  
UPPER LINK AND  
TIE ROD  
LINK ARM  
(opt)

ANTI-DUMPING  
SYSTEM  
(opt.)

**2300 Kg**  
TO THE BALL  
JOINTS

JOYSTICK





# ABSOLUTE COMFORT

The pleasure of working with a Volcan 85 is not only offered by the machine's performance but also by the driver's comfort.

The driving position is comprised of a **platform suspended on silent-block** to reduce vibrations and noise.

The **brakes and clutch pedals have been redesigned** to guarantee greater comfort of use.

The controls are set up ergonomically and easy to be operated, and from the **operator's seat there is a full unobstructed view** of both machine and implement.

## STANDARD REVERSIBILITY

Just in a few seconds the operator can rotate the driving platform by 180°, composed of seat, steering wheel, dashboard and suspended pedals, **to work with a front-mounted implement and steadily supervising all working operations, favouring comfort and safety.**



# HOMOLOGATED CABINS

Designed and built with extreme attention to the smallest details to guarantee pleasant living of the interior and without damaging the rich environment of vegetation that one is operating in.

The steel monocoque structure is built on a **suspended on silent-block platform**, completely independent of the tractor's chassis.

The standard set-up offers every comfort: ventilation, heating and air conditioning system, fabric seat, inside lighting, roll-up sun-shade, car radio set-up and 12 V single-pole outlet to power tools, joystick or additional monitor.

Available in 2 versions:

- VISTA CLIMA** with 4-upright, the cabin features a conical and compact profile to easily work in tight rows, also on side slopes and in vegetation-rich environments. Thanks to the large all-glass doors, it offers a 360° unobstructed view of the surroundings, wheel track and attachment.
- SPACE CLIMA** with 6-upright, the cabin is characterised by a very generous living space thanks to a larger platform, and offers excellent ergonomics in both front-drive and reverse driver's seat position.

		VOLCAN 85			
		AR	RS	DS®	MT
VISTA CLIMA CABIN	Air-conditioning				
	4-upright	✓	✓	✓	
	Conical structure				
SPACE CLIMA CABIN	Air-conditioning				
	6-upright		✓		✓
	Standard structure				



# VOLCAN 85 AR

## Data Sheet

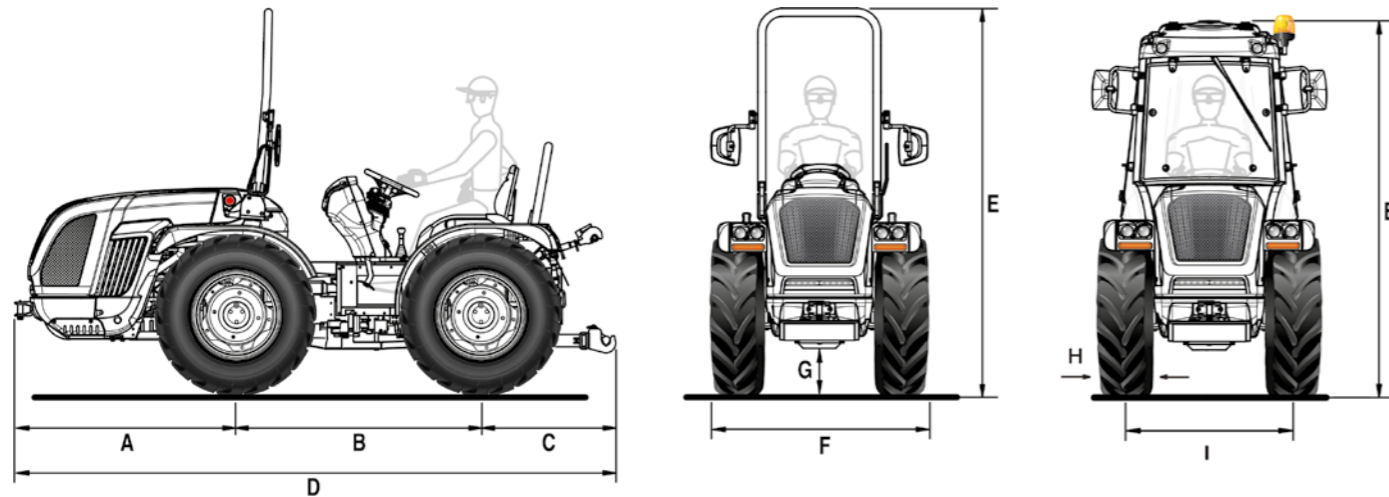

A	B	C	D	E min/max (with roll-bar)	E min/max (con cab)	F min/max	G min/max
1348	1495	932	3775	2254 / 2364	2139 / 2249	1127 / 1603	161 / 271

\* Dimensions in mm

	250/80-18	280/70 R18	280/70 R18 Galaxy Garden	320/65 R18	250/85 R20
	with adjustable rim	with adjustable rim	with adjustable rim	with adjustable rim	with adjustable rim
H	240	282	282	320	245
I	898 / 1112	1022 / 1112	1022 / 1112	1022 / 1112	882 / 1230
F	1138 / 1352	1304 / 1394	1304 / 1394	1342 / 1432	1127 / 1475

	300/70 R20	300/70 R20 Galaxy Garden	340/65 R20	31x15.50-15 XTC	33x12.50-15 T413
	with adjustable rim	with adjustable rim	with adjustable rim	with fixed rim	with fixed rim
H	286	286	343	368	325
I	996 / 1260	996 / 1260	996 / 1260	1016	959 / 965
F	1282 / 1546	1282 / 1546	1339 / 1603	1384	1284 / 1290

\* Dimensions in mm - min / max  
H = Tyre width - I = Wheel track - F = Tractor width

TECHNICAL FEATURES	VOLCAN 85 AR
<b>ENGINE</b>	Kohler KDI 2504 TCR
No. of cylinders	4 in-line / 16 valves
Displacement (cc)	2482
Intake	Turbo / Intercooler
Fuel system	"Common rail" direct injection - 2000 bar
Emissions compliance	Stage V
Balancing	Counter-balance shafts
Power (kW/hp)	55.4 / 75.3
Rated speed (rpm)	2300
Max torque (Nm/rpm)	300 / 1500
Engine speed management	Electronically regulated via a console with functions for: increase and decrease engine speed, memorize and recall the set speed, switch off and switch to minimum speed
Cooling	Liquid
Tank capacity (l)	58
<b>CHASSIS</b>	Swinging integral chassis (±15°) OS-FRAME with central articulation
<b>DRIVE</b>	Four-wheel drive. Front-wheel drive disengagement with electro-hydraulic control
<b>TRANSMISSION</b>	32-speed synchronised gearbox: 16 FWD and 16 REV with synchronised reverser
Min/max travel speed (km/h)	0.7 / 38
<b>POWER SHUTTLE EASYDRIVE® (optional)</b>	Electro-hydraulic power shuttle electronically actuated with the lever (three-position FWD-N-REV) located on the left of steering wheel. Possibility to choose from 5 levels of reactivity
Transmission clutch	Multidisc in oil bath with electronically-managed and proportional hydraulic control. Power Clutch System button for engaging gears and reverser without using the clutch pedal. PRO-ACT System clutch pedal with Easy Plus™ assisted engagement. Smart Brake & Go function for automatic clutch management only with the brake pedal.
<b>DIFFERENTIAL</b>	Front and rear. Differential lock: front and rear simultaneously or rear only with electro-hydraulic control
<b>AXLES</b>	Front and rear with planetary reduction units
<b>REAR PTO</b>	Independent from the gearbox and synchronised with the forwarding speed. Negative safety hydraulic brake to stop the PTO
<b>PTO clutch</b>	Multidisc in oil bath with electro-hydraulic control
PTO rotation speed (rpm)	Standard: 540/540E - Optional: 540/1000
<b>HYDRAULIC SYSTEM</b>	Dual circuit with independent pumps and heat exchanger
Flow rate to the hydroguide and the electro-hydraulic controls (l/min)	33.5
Flow rate to the lift and the control valves (l/min)	29.5 (optional oversized pump with 51 l/min flow rate)
Maximum hydraulic pressure (bar)	180
<b>REAR CONTROL VALVES</b>	Mechanically controlled
Standard	2 double-acting + free flow oil return (total 5 hydraulic outlets)
Optional and in addition to the standard ones	1 single-acting and 1 double-acting (8 hydraulic outlets in total) or 1 double-acting and 1 double-acting with float (total 9 hydraulic outlets)
Joystick (optional)	Proportional electronic control of lifts and rear control valves consisting of: 1 continuous flow with adjustable flow rate and free flow oil return, 5 double-acting (replacing the standard ones) and oversized pump. Potentiometer for adjusting joystick sensitivity. Remote control for PTO engagement. Storage armrest
<b>REAR LIFT</b>	By two external rams. Standard: raising/lowering - Optional: position and draft control
3-point implement hitch	Standard: Normal couplings cat. 1 and 2. Optional: Quick-couplings cat. 1 and 2, L-shaped, arms adjustable in length and hooks adjustable in width
Third point tie rod	Standard: with manual adjustment - Optional: hydraulically controlled upper link and tie rod link arm
Ball joint lifting capacity (kg)	2300
<b>FRONT LIFT (optional)</b>	Two rams with front protection and 2 double-acting control valves (total 4 front hydraulic outlets)
Third point arms	Rigid with quick-couplings cat. 1 and 2
Lifting capacity (kg)	800
<b>DRIVING POSITION</b>	Reversible with rotating platform suspended on silent blocks. Suspended pedals mounted on the rotating control tower
Steering wheel	Tilt adjustable
Seat	With gas spring for easy tipping, safety belt and man-on-board sensor. - Standard: comfort seat with adjustable spring tension according to the operator's weight - Optional: 'Kab Seating', 'Grammer' or 'Cobo' pneumatic seat
<b>SERVICE BRAKES</b>	Oil bath discs with hydrostatic control, acting on the four wheels with automatic engagement of the 4-wheel drive
Parking brake	Automatic and independent Brake-Off acting as emergency brake with proportional action
<b>STEERING</b>	Hydrostatic steering acting on the central joint. Flow deviator for steering unit
<b>SAFETY</b>	Standard: front homologated roll-bar with gas springs for easy lowering and lifting
<b>CABIN (optional)</b>	VISTA CLIMA with 4-upright and conical structure, homologated and soundproofed with monocoque body mounted on silent-blocks, beacon lamp and fabric seat. Ventilation, heating and air-conditioning system. Car radio preparation. Optional: active carbon filters
<b>DASHBOARD</b>	With TFT colour display showing: hours of operation, engine rpm, forwarding speed, PTO rpm, particulate filter clogging level, instantaneous fuel consumption, battery voltage and current time. Analogue instrumentation complete with engine rpm, engine coolant temperature and fuel level indicator. Warning lights and acoustic alarm
<b>ELECTRIC SYSTEM</b>	Battery 80 Ah / 12 V - Alternator 95 A
Standard equipment	Vehicle Control Unit, street light and indicator system, front LED working lights, single-pole dashboard socket, rear 7-pin and 3-pin sockets
<b>TYRES</b>	250/80-18 * 280/70R18 * 280/70R18 Galaxy Garden * 320/65R18 * 250/85R20 * 300/70R20 * 300/70R20 Galaxy Garden * 340/65R20 * 31x15.50-15 XTC * 33x12.50-15 T413
<b>TOW HOOKS (standard)</b>	Front - Rear CUNA cat. C adjustable in height
Optional	Rear tow hook: EC approved or EC with Slider frame or CUNA with Slider frame or EC tow bar with Slider frame
<b>RUNNING ORDER WEIGHT</b>	With roll-bar (kg): 2240 kg - With cab: 2390 kg
<b>ADDITIONAL OPTIONS</b>	Front bumper, beacon lamp, rear adjustable working light, Self Cleaning System™, front weights 150 kg and wheel weights 50 kg each, anti-dumping system, black and white 'Special Edition' livery

# VOLCAN 85 RS

## Data Sheet

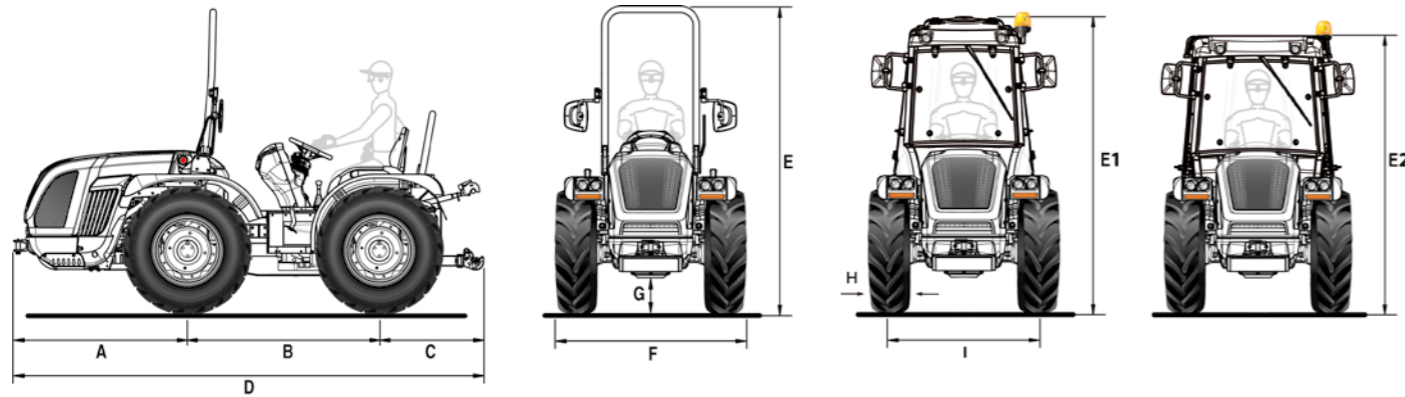

A	B	C	D	E min/max (con roll-bar)	E1 min/max (con VISTA cab)	E2 min/max (con SPACE cab)	F min/max	G min/max
1348	1495	932	3775	2254 / 2364	2139 / 2249	2070 / 2180	1296 / 1961	161 / 271

\* Dimensions in mm

	340/65 R18	280/70 R18	280/70 R18 Galaxy Garden	320/65 R18	250/85 R20	300/70 R20	300/70R20 Galaxy Garden
	with adjustable rim	with adjustable rim	with adjustable rim	with adjustable rim	with adjustable rim	with adjustable rim	with adjustable rim
H	343	282	282	320	245	286	286
I	1166 / 1470	1098 / 1538	1098 / 1538	1166 / 1470	1046 / 1588	1134 / 1618	1134 / 1618
F	1509 / 1813	1380 / 1820	1380 / 1820	1486 / 1790	1296 / 1838	1420 / 1904	1420 / 1904

	320/70 R20	340/65 R20	31x15.50-15 XTC	31x15.50-15 STG	33x15.50-15 XTC	13.6-16 Garden
	with adjustable rim	with adjustable rim	with fixed rim	with fixed rim	with fixed rim	with fixed rim
H	316	343	368	394	391	391
I	1134 / 1618	1134 / 1618	1260 / 1374	1260 / 1374	1260 / 1374	1240 / 1400
F	1450 / 1934	1477 / 1961	1628 / 1742	1654 / 1768	1651 / 1765	1631 / 1791

\* Dimensions in mm - min / max  
H = Tyre width - I = Wheel track - F = Tractor width

TECHNICAL FEATURES	VOLCAN 85 RS
<b>ENGINE</b>	Kohler KDI 2504 TCR
No. of cylinders	4 in-line / 16 valves
Displacement (cc)	2482
Intake	Turbo / Intercooler
Fuel system	"Common rail" direct injection - 2000 bar
Emissions compliance	Stage V
Balancing	Counter-balance shafts
Power (kW/hp)	55.4 / 75.3
Rated speed (rpm)	2300
Max torque (Nm/rpm)	300 / 1500
Engine speed management	Electronically regulated via a console with functions for: increase and decrease engine speed, memorize and recall the set speed, switch off and switch to minimum speed
Cooling	Liquid
Tank capacity (l)	58
<b>CHASSIS</b>	Swinging integral chassis (±15°) OS-FRAME with steering wheels
<b>DRIVE</b>	Four-wheel drive. Front-wheel drive disengagement with electro-hydraulic control
<b>TRANSMISSION</b>	32-speed synchronised gearbox: 16 FWD and 16 REV with synchronised reverser
Min/max travel speed (km/h)	0.7 / 40
<b>POWER SHUTTLE EASYDRIVE® (optional)</b>	Electro-hydraulic power shuttle electronically actuated with the lever (three-position FWD-N-REV) located on the left of steering wheel. Possibility to choose from 5 levels of reactivity
Transmission clutch	Multidisc in oil bath with electronically-managed and proportional hydraulic control. - Power Clutch System button for engaging gears and reverser without using the clutch pedal. - PRO-ACT System clutch pedal with Easy Plus™ assisted engagement. - Smart Brake & Go function for automatic clutch management only with the brake pedal.
<b>DIFFERENTIAL</b>	Front and rear. Differential lock: front and rear simultaneously or rear only with electro-hydraulic control
<b>AXLES</b>	Front and rear with planetary reduction units
<b>REAR PTO</b>	Independent from the gearbox and synchronised with the forwarding speed. Negative safety hydraulic brake to stop the PTO
<b>PTO clutch</b>	Multidisc in oil bath with electro-hydraulic control
PTO rotation speed (rpm)	Standard: 540/540E - Optional: 540/1000
<b>HYDRAULIC SYSTEM</b>	Dual circuit with independent pumps and heat exchanger
Flow rate to the hydroguide and the electro-hydraulic controls (l/min)	33.5
Flow rate to the lift and the control valves (l/min)	29.5 (optional oversized pump with 51 l/min flow rate)
Maximum hydraulic pressure (bar)	180
<b>REAR CONTROL VALVES</b>	Mechanically controlled
Standard	2 double-acting + free flow oil return (total 5 hydraulic outlets)
Optional and in addition to the standard ones	1 single-acting and 1 double-acting (8 hydraulic outlets in total) or 1 double-acting and 1 double-acting with float (total 9 hydraulic outlets)
Joystick (optional)	Proportional electronic control of lifts and rear control valves consisting of: 1 continuous flow with adjustable flow rate and free flow oil return, 5 double-acting (replacing the standard ones) and oversized pump. Potentiometer for adjusting joystick sensitivity. Remote control for PTO engagement. Storage armrest
<b>REAR LIFT</b>	By two external rams. Standard: raising/lowering - Optional: position and draft control
3-point implement hitch	Standard: Normal couplings cat. 1 and 2. Optional: Quick-couplings cat. 1 and 2, arms adjustable in length or Quick-couplings cat. 1 and 2, L-shaped, arms adjustable in length and hooks adjustable in width
Third point tie rod	Standard: with manual adjustment - Optional: hydraulically controlled upper link and tie rod link arm
Ball joint lifting capacity (kg)	2300
<b>FRONT LIFT (optional)</b>	Two rams with front protection and 2 double-acting control valves (total 4 front hydraulic outlets)
Third point arms	Rigid with quick-couplings cat. 1 and 2
Lifting capacity (kg)	800
<b>DRIVING POSITION</b>	Reversible with rotating platform suspended on silent blocks. Suspended pedals mounted on the rotating control tower
Steering wheel	Tilt adjustable
Seat	With gas spring for easy tipping, safety belt and man-on-board sensor. - Standard: comfort seat with adjustable spring tension according to the operator's weight - Optional: 'Kab Seating', 'Grammer' or 'Cobo' pneumatic seat
<b>SERVICE BRAKES</b>	Oil bath discs with hydrostatic control, acting on the four wheels with automatic engagement of the 4-wheel drive. Independent manoeuvring brakes acting on the rear wheels
Parking brake	Automatic and independent Brake-Off acting as emergency brake with proportional action
<b>STEERING</b>	Hydrostatic steering acting on the front wheels. Flow deviator for steering unit
<b>SAFETY</b>	Standard: front homologated roll-bar with gas springs for easy lowering and lifting
<b>CABIN (optional)</b>	Homologated and soundproof with monocoque body mounted on silent-blocks, beacon lamp and fabric seat. Ventilation, heating and air-conditioning system. Car radio preparation. Available with 6-upright structure (SPACE CLIMA) or 4-upright conical structure (VISTA CLIMA). Optional: active carbon filters
<b>DASHBOARD</b>	With TFT colour display showing: hours of operation, engine rpm, forwarding speed, PTO rpm, particulate filter clogging level, instantaneous fuel consumption, battery voltage and current time. Analogue instrumentation complete with engine rpm, engine coolant temperature and fuel level indicator. Warning lights and acoustic alarm
<b>ELECTRIC SYSTEM</b>	Battery 80 Ah / 12 V - Alternator 95 A
Standard equipment	Vehicle Control Unit, street light and indicator system, front LED working lights, single-pole dashboard socket, rear 7-pin and 3-pin sockets
<b>TYRES</b>	340/65R18 * 280/70R18 * 280/70R18 Galaxy Garden * 320/65R18 * 250/85R20 * 300/70R20 * 300/70R20 Galaxy Garden * 320/70R20 * 340/65R20 * 31x15.50-15 XTC or STG * 33x15.50-15 XTC * 13.6-16 Garden
<b>TOW HOOKS (standard)</b>	Front - Rear CUNA cat. C adjustable in height
Optional	Rear tow hook: EC approved or EC with Slider frame or CUNA with Slider frame or EC tow bar with Slider frame
<b>RUNNING ORDER WEIGHT</b>	With roll-bar (kg): 2320 kg - With cab: 2470 kg
<b>ADDITIONAL OPTIONS</b>	HDR hydraulic suspension with accumulator including: 2 double-acting (control valves replacing the standard ones), front bumper, beacon lamp, rear adjustable working light, Self Cleaning System™, front weights 150 kg and wheel weights 50 kg each, anti-dumping system, black and white 'Special Edition' livery



## VOLCAN 85 DUALSTEER®

## Data Sheet

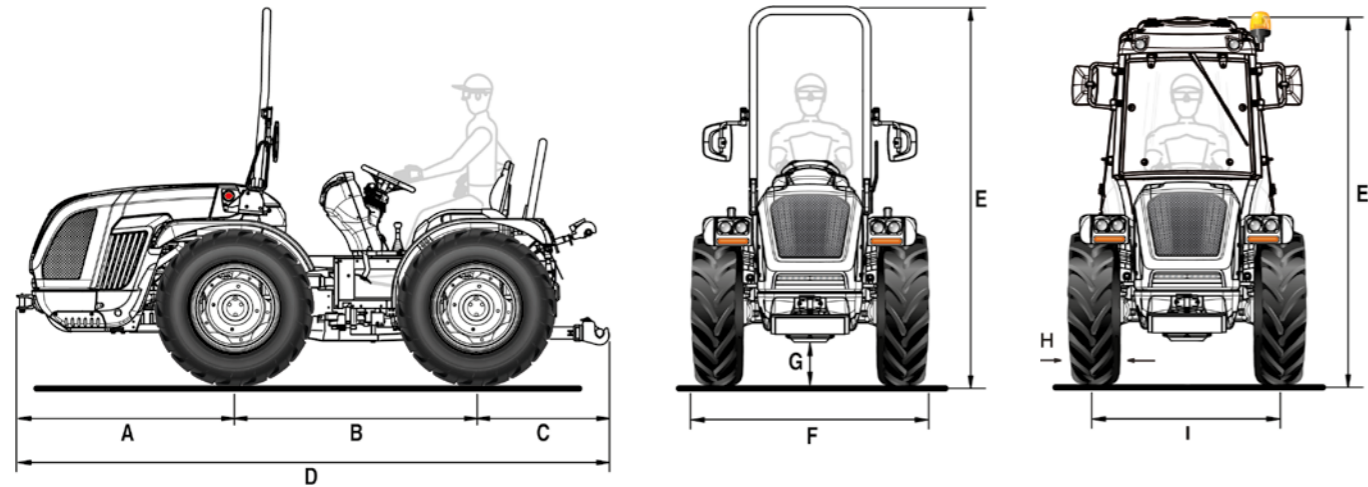

A	B	C	D	E min/max (with roll-bar)	E min/max (con cab)	F min/max	G min/max
1348	1495	932	3775	2254 / 2364	2139 / 2249	1296 / 1961	161 / 271

\* Dimensions in mm

	340/65 R18	280/70 R18	280/70 R18 Galaxy Garden	320/65 R18	250/85 R20	300/70 R20
	with adjustable rim	with adjustable rim	with adjustable rim	with adjustable rim	with adjustable rim	with adjustable rim
H	343	282	282	320	245	286
I	1166 / 1470	1098 / 1538	1098 / 1538	1166 / 1470	1046 / 1588	1134 / 1618
F	1509 / 1813	1380 / 1820	1380 / 1820	1486 / 1790	1296 / 1838	1420 / 1904

	300/70R20 Galaxy Garden	320/70 R20	340/65 R20	31x15.50-15 XTC	31x15.50-15 STG	33x15.50-15 XTC
	with adjustable rim	with adjustable rim	with adjustable rim	with fixed rim	with fixed rim	with fixed rim
H	286	316	343	368	394	391
I	1134 / 1618	1134 / 1618	1134 / 1618	1260 / 1374	1260 / 1374	1260 / 1374
F	1420 / 1904	1450 / 1934	1477 / 1961	1628 / 1742	1654 / 1768	1651 / 1765

\* Dimensions in mm - min / max

H = Tyre width - I = Wheel track - F = Tractor width

TECHNICAL FEATURES	VOLCAN 85 DUALSTEER®
<b>ENGINE</b>	Kohler KDI 2504 TCR
No. of cylinders	4 in-line / 16 valves
Displacement (cc)	2482
Intake	Turbo / Intercooler
Fuel system	"Common rail" direct injection - 2000 bar
Emissions compliance	Stage V
Balancing	Counter-balance shafts
Power (kW/hp)	55.4 / 75.3
Rated speed (rpm)	2300
Max torque (Nm/rpm)	300 / 1500
Engine speed management	Electronically regulated via a console with functions for: increase and decrease engine speed, memorize and recall the set speed, switch off and switch to minimum speed
Cooling	Liquid
Tank capacity (l)	58
<b>CHASSIS</b>	Swinging integral chassis (±15°) OS-FRAME with central articulation and steering wheels
<b>DRIVE</b>	Four-wheel drive. Front-wheel drive disengagement with electro-hydraulic control
<b>TRANSMISSION</b>	32-speed synchronised gearbox: 16 FWD and 16 REV with synchronised reverser
Min/max travel speed (km/h)	0.7 / 40
<b>POWER SHUTTLE EASYDRIVE® (optional)</b>	Electro-hydraulic power shuttle electronically actuated with the lever (three-position FWD-N-REV) located on the left of steering wheel. Possibility to choose from 5 levels of reactivity
Transmission clutch	Multidisc in oil bath with electronically-managed and proportional hydraulic control. Power Clutch System button for engaging gears and reverser without using the clutch pedal. PFO-ACT System clutch pedal with Easy Plus™ assisted engagement. Smart Brake & Go function for automatic clutch management only with the brake pedal.
<b>DIFFERENTIAL</b>	Front and rear. Differential lock: front and rear simultaneously or rear only with electro-hydraulic control
<b>AXLES</b>	Front and rear with planetary reduction units
<b>REAR PTO</b>	Independent from the gearbox and synchronised with the forwarding speed. Negative safety hydraulic brake to stop the PTO
<b>PTO clutch</b>	Multidisc in oil bath with electro-hydraulic control
PTO rotation speed (rpm)	Standard: 540/540E - Optional: 540/1000
<b>HYDRAULIC SYSTEM</b>	Dual circuit with independent pumps and heat exchanger
Flow rate to the hydroguide and the electro-hydraulic controls (l/min)	33.5
Flow rate to the lift and the control valves (l/min)	29.5 (optional oversized pump with 51 l/min flow rate)
Maximum hydraulic pressure (bar)	180
<b>REAR CONTROL VALVES</b>	Mechanically controlled
Standard	2 double-acting + free flow oil return (total 5 hydraulic outlets)
Optional and in addition to the standard ones	1 single-acting and 1 double-acting (8 hydraulic outlets in total) or 1 double-acting and 1 double-acting with float (total 9 hydraulic outlets)
Joystick (optional)	Proportional electronic control of lifts and rear control valves consisting of: 1 continuous flow with adjustable flow rate and free flow oil return, 5 double-acting (replacing the standard ones) and oversized pump. Potentiometer for adjusting joystick sensitivity. Remote control for PTO engagement. Storage armrest
<b>REAR LIFT</b>	By two external rams. Standard: raising/lowering - Optional: position and draft control
3-point implement hitch	Standard: Normal couplings cat. 1 and 2. Optional: Quick-couplings cat. 1 and 2, arms adjustable in length or Quick-couplings cat. 1 and 2, L-shaped, arms adjustable in length and hooks adjustable in width
Third point tie rod	Standard: with manual adjustment - Optional: hydraulically controlled upper link and tie rod link arm
Ball joint lifting capacity (kg)	2300
<b>FRONT LIFT (optional)</b>	Two rams with front protection and 2 double-acting control valves (total 4 front hydraulic outlets)
Third point arms	Rigid with quick-couplings cat. 1 and 2
Lifting capacity (kg)	800
<b>DRIVING POSITION</b>	Reversible with rotating platform suspended on silent blocks. Suspended pedals mounted on the rotating control tower
Steering wheel	Tilt adjustable
Seat	With gas spring for easy tipping, safety belt and man-on-board sensor. - Standard: comfort seat with adjustable spring tension according to the operator's weight - Optional: 'Kab Seating', 'Grammer' or 'Cobo' pneumatic seat
<b>SERVICE BRAKES</b>	Oil bath discs with hydrostatic control, acting on the four wheels with automatic engagement of the 4-wheel drive. Independent manoeuvring brakes acting on the rear wheels
Parking brake	Automatic and independent Brake-Off acting as emergency brake with proportional action
<b>STEERING</b>	Double steering system Dualsteer® with 4-cylinders. Hydrostatic steering acting on front wheels and central joint. Flow deviator for steering unit
<b>SAFETY</b>	Standard: front homologated roll-bar with gas springs for easy lowering and lifting
<b>CABIN (optional)</b>	VISTA CLIMA with 4-upright and conical structure, homologated and soundproofed with monocoque body mounted on silent-blocks, beacon lamp and fabric seat. Ventilation, heating and air-conditioning system. Car radio preparation. Optional: active carbon filters
<b>DASHBOARD</b>	With TFT colour display showing: hours of operation, engine rpm, forwarding speed, PTO rpm, particulate filter clogging level, instantaneous fuel consumption, battery voltage and current time. Analogue instrumentation complete with engine rpm, engine coolant temperature and fuel level indicator. Warning lights and acoustic alarm
<b>ELECTRIC SYSTEM</b>	Battery 80 Ah / 12 V - Alternator 95 A
Standard equipment	Vehicle Control Unit, street light and indicator system, front LED working lights, single-pole dashboard socket, rear 7-pin and 3-pin sockets
<b>TYRES</b>	340/65R18 * 280/70R18 * 280/70R18 Galaxy Garden * 320/65R18 * 250/85R20 * 300/70R20 * 300/70R20 Galaxy Garden * 320/70R20 * 340/65R20 * 31x15.50-15 XTC or STG * 33x15.50-15 XTC
<b>TOW HOOKS (standard)</b>	Front - Rear CUNA cat. C adjustable in height
Optional	Rear tow hook: EC approved or EC with Slider frame or CUNA with Slider frame or EC tow bar with Slider frame
<b>RUNNING ORDER WEIGHT</b>	With roll-bar (kg): 2390 kg - With cab: 2540 kg
<b>ADDITIONAL OPTIONS</b>	HDR hydraulic suspension with accumulator including: 2 double-acting (control valves replacing the standard ones), front bumper, beacon lamp, rear adjustable working light, Self Cleaning System™, front weights 150 kg and wheel weights 50 kg each, anti-dumping system, black and white 'Special Edition' livery



# VOLCAN 85 MT

## Data Sheet

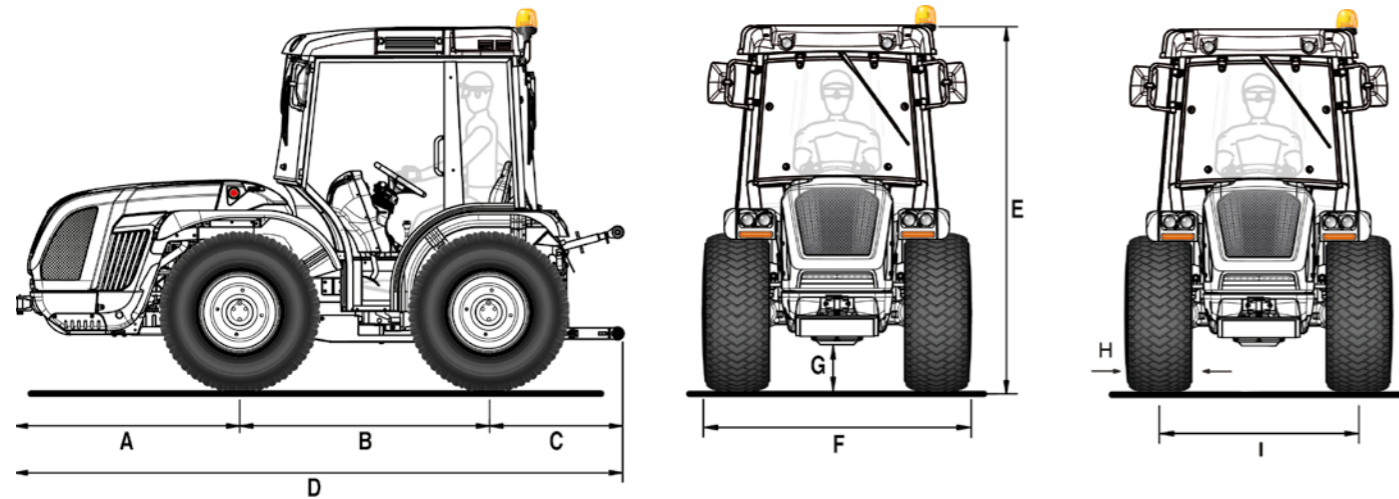

A	B	C	D	E min/max	F min/max	G min/max
1348	1495	932	3775	2070 / 2180	1697 / 1961	161 / 271

\* Dimensions in mm

	31x15.50-15 XTC	31x15.50-15 STG	33x15.50-15 XTC	440/50 R17 All-Ground	340/65 R20
	with fixed rim	with fixed rim	with fixed rim	with fixed rim	with adjustable rim
H	368	394	391	431	343
I	1510	1510	1510	1476	1354 / 1618
F	1878	1904	1901	1907	1697 / 1961

\* Dimensions in mm - min / max  
H = Tyre width - I = Wheel track - F = Tractor width

TECHNICAL FEATURES	VOLCAN 85 MT
<b>ENGINE</b>	Kohler KDI 2504 TCR
No. of cylinders	4 in-line / 16 valves
Displacement (cc)	2482
Intake	Turbo / Intercooler
Fuel system	"Common rail" direct injection - 2000 bar
Emissions compliance	Stage V
Balancing	Counter-balance shafts
Power (kW/hp)	55.4 / 75.3
Rated speed (rpm)	2300
Max torque (Nm/rpm)	300 / 1500
Engine speed management	Electronically regulated via a console with functions for: increase and decrease engine speed, memorize and recall the set speed, switch off and switch to minimum speed
Cooling	Liquid
Self Cleaning System™	Automatic radiator and engine intake grille cleaning system to prevent overheating
Tank capacity (l)	58
<b>CHASSIS</b>	Swinging integral chassis (±15°) OS-FRAME with steering wheels
<b>DRIVE</b>	Four-wheel drive. Front-wheel drive disengagement with electro-hydraulic control
<b>TRANSMISSION</b>	32-speed synchronised gearbox: 16 FWD and 16 REV with synchronised reverser
Min/max travel speed (km/h)	0.7 / 40
<b>POWER SHUTTLE EASYDRIVE® (optional)</b>	Electro-hydraulic power shuttle electronically actuated with the lever (three-position FWD-N-REV) located on the left of steering wheel. Possibility to choose from 5 levels of reactivity
Transmission clutch	Multidisc in oil bath with electronically-managed and proportional hydraulic control. Power Clutch System button for engaging gears and reverser without using the clutch pedal. PRO-ACT System clutch pedal with Easy Plus™ assisted engagement. Smart Brake & Go function for automatic clutch management only with the brake pedal.
<b>DIFFERENTIAL</b>	Front and rear. Differential lock: front and rear simultaneously or rear only with electro-hydraulic control
<b>AXLES</b>	Front and rear with planetary reduction units
<b>REAR PTO</b>	Independent from the gearbox and synchronised with the forwarding speed. Negative safety hydraulic brake to stop the PTO
PTO clutch	Multidisc in oil bath with electro-hydraulic control
PTO rotation speed (rpm)	Standard: 540/1000
<b>HYDRAULIC SYSTEM</b>	Dual circuit with independent pumps and heat exchanger
Flow rate to the hydroguide and the electro-hydraulic controls (l/min)	33.5
Flow rate to the lift and the control valves (l/min)	29.5
<b>Maximum hydraulic pressure (bar)</b>	180
<b>REAR CONTROL VALVES</b>	Mechanically controlled
Standard	1 single-acting and 2 double-acting + free flow oil return (total 6 hydraulic outlets)
Optional and in addition to the standard ones	1 single-acting (total of 7 hydraulic outlets) or 1 double-acting (total of 8 hydraulic outlets) or 1 double-acting with float (total of 8 hydraulic outlets)
Joystick (optional)	Proportional electronic control of lifts and rear control valves consisting of: 1 single-acting and 3 double-acting (replacing the standard ones). Potentiometer for adjusting joystick sensitivity. Remote control for PTO engagement. Storage armrest
<b>REAR LIFT</b>	Four external rams with Dual Floating System® hydraulic suspension
3-point implement hitch	Quick-couplings cat. 1 and 2, L-shaped, arms adjustable in length and hooks adjustable in width
Third point tie rod	Standard: with manual adjustment - Optional: hydraulically controlled upper link and tie rod link arm
Ball joint lifting capacity (kg)	2300
<b>FRONT LIFT (optional)</b>	Two rams with front protection and 2 double-acting control valves (total 4 front hydraulic outlets)
Third point arms	Rigid with quick-couplings cat. 1 and 2
Lifting capacity (kg)	800
<b>DRIVING POSITION</b>	Wide platform suspended on silent blocks, reversible driver's seat with suspended pedals mounted on rotating control tower
Steering wheel	Tilt adjustable
Seat	With gas spring for easy tipping, safety belt and man-on-board sensor. - Standard: comfort seat with adjustable spring tension according to the operator's weight - Optional: "Grammer" or "Cobo" pneumatic seat
<b>SERVICE BRAKES</b>	Oil bath discs with hydrostatic control, acting on the four wheels with automatic engagement of the 4-wheel drive. Independent manoeuvring brakes acting on the rear wheels
Parking brake	Automatic and independent Brake-Off acting as emergency brake with proportional action
<b>STEERING</b>	Hydrostatic steering acting on the front wheels. Flow deviator for steering unit
<b>SAFETY</b>	Standard: 6-upright semi-cab and beacon lamp
<b>CABIN (optional)</b>	SPACE CLIMA with 6-upright, homologated and soundproofed with monocoque body mounted on silent blocks, beacon lamp and fabric seat. Ventilation, heating and air-conditioning system. Car radio preparation. Optional: active carbon filters
<b>DASHBOARD</b>	With TFT colour display showing: hours of operation, engine rpm, forwarding speed, PTO rpm, particulate filter clogging level, instantaneous fuel consumption, battery voltage and current time. Analogue instrumentation complete with engine rpm, engine coolant temperature and fuel level indicator. Warning lights and acoustic alarm
<b>ELECTRIC SYSTEM</b>	Battery 80 Ah / 12 V - Alternator 95 A
Standard equipment	Vehicle Control Unit, street light and indicator system, front LED working lights, single-pole dashboard socket, rear 7-pin and 3-pin sockets
<b>TYRES</b>	31x15.50-15 XTC or STG * 33x15.50-15 XTC * 440/50-17 All-Ground * 340/65R20
<b>TOW HOOKS (standard)</b>	Front - Rear CUNA cat. C adjustable in height
Optional	Rear tow hook: EC approved or EC with Slider frame or CUNA with Slider frame or EC tow bar with Slider frame
<b>RUNNING ORDER WEIGHT</b>	With roll-bar (kg): 2420 kg - With cab: 2500 kg
<b>ADDITIONAL OPTIONS</b>	Front bumper, front weights 150 kg and wheel weights 50 kg each, anti-dumping system, black and white 'Special Edition' livery



## THE SERVICES

---



### SPARE PARTS

A complete range of original spare parts, guaranteed directly by the manufacturer.



### ASSISTANCE

A team of specialists, well prepared and available to assure an efficient and resolving service.



### LUBRICANTS

We recommend to use the original PowerLube lubricants.



### FINANCIAL SERVICES

Financial solutions to meet the credit requirements.



MADE IN ITALY